

TIMBER GRAB 4.0



Application:

The Hauer timber grab is designed for logging applications and attachment to three-point linkages.

Description:

The Hauer timber grab consists of a grapple and a sturdy blade with a serrated edge that fixes the logs and ensures safe handling. The boom is made from hexagonal box steel and is lined with plastic sliders that minimise wear as the boom extends and retracts using self-centring technology. Extending up to 700mm, it reaches even those logs that would otherwise be out of reach for the grapple. This suspends from a high-quality 4.5t continuous rotator with a special joint that ensures the rotator is exposed to pulling rather than shearing forces, avoiding the risk of damage during logging. The grapple itself is made of high-strength and fine-grained steel that gives maximum stability. All pivot pins have lubricated bronze bushings.

Advantages:

- Large jaw and high grip grapple
- Large boom pivoting range (45° left/right)
- Massive continuous rotator with pendulum joint
- Long boom extension
- Blade with integral serrated edge fixing logs in place
- Perfectly protected oil lines
- Bronze bushed pivot pins



INNOVATION MIT TRADITION FÜRS LEBEN.

Standard Specification:

- 3-point linkage, cat. 2 couplers
- Standard Hauer orange or Hauer matt black paint finish (all RAL colours are an option)
- Telescoping and pivoting boom
- Pivoting joint restricts the load on the rotator to tensile loading
- Continuous rotator 4.5t
- Grapple
- Oil lines to tractor
- Guard blade
- Standard tapered couplers
- All functions are controlled from a mechanical joystick (via cables)

Options:

- 200m blade wing extension
- 3-point linkage, cat 3 (blade with extended wings only)
- Top link control from mech. joystick
- Paint finish available in all RAL colours

Technical Data:

Max. jaw opening mm	Volume m ²	Gripping pressure t	Weight kg	Pivoting range °	Extension mm	Rotator t
1450	0,23	9	442	45	700	4,5

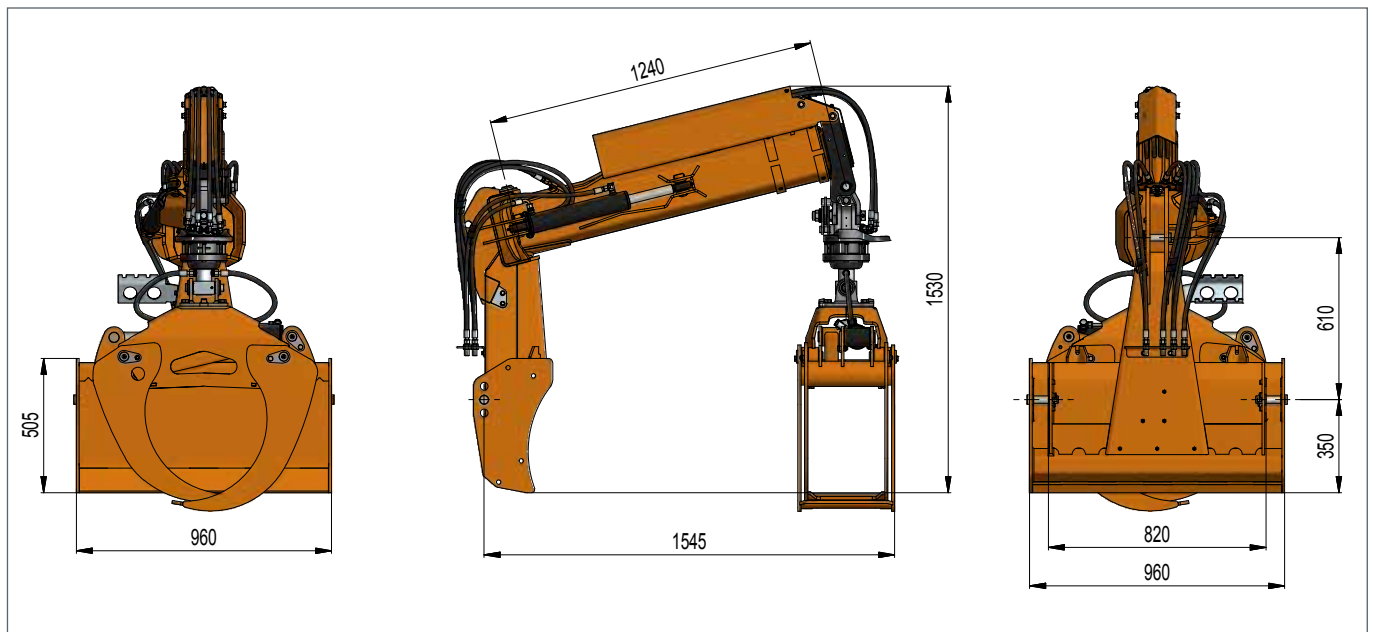

© Hauer 07/2020. The illustrated products may differ from standard specification products. Subject to errors and changes.



Franz Hauer GmbH & CoKG, A-3125 Statzendorf, Werksstraße 6,

Tel.: +43 / (0)2786 / 7104-0, Fax: +43 / (0)2786 / 7104-15, info@hfl.co.at | www.hfl.co.at