

BIG-BAG-LIFTER



Application:

The Hauer – Big-Bag-Lifter was especially developed for the attachment and transport of Big-Bags with one or more loops.

Description:

The Big-Bag-Lifter has one vertical standing arm with a left bended hook at the end. This curvy shape facilitates the view on the top to easily put up Big Bags, especially when using a telescopic loader.

A high load capacity ensures the transport of large Big-Bags too.

The coupling plates are screwed on the frame and can be therefore changed very quickly and with low effort.

Advantages:

- good view of the top of the hook by bent shape
- putting up and putting down of Big Bags without getting off the tractor
- screwed coupling plates for quick change

Type:

- Standard SWE-B Hauer or SWE-Euro (optional many common attachment systems)
- Standard Hauer orange or Hauer black matt (optional all RAL colours)

Technical Data	Load Capacity kg	Weight kg
Big-Bag-Lifter - BBL	1000	119



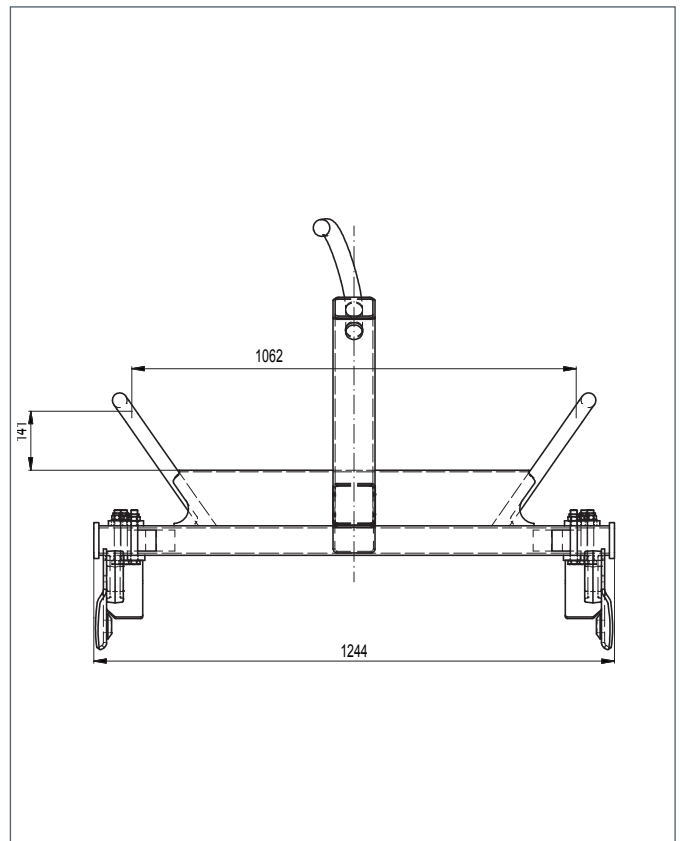
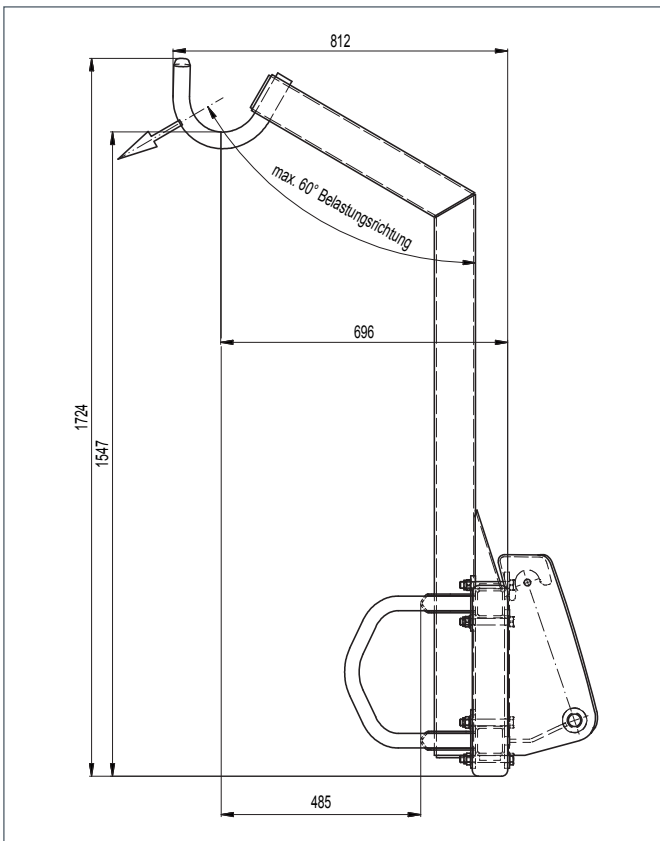
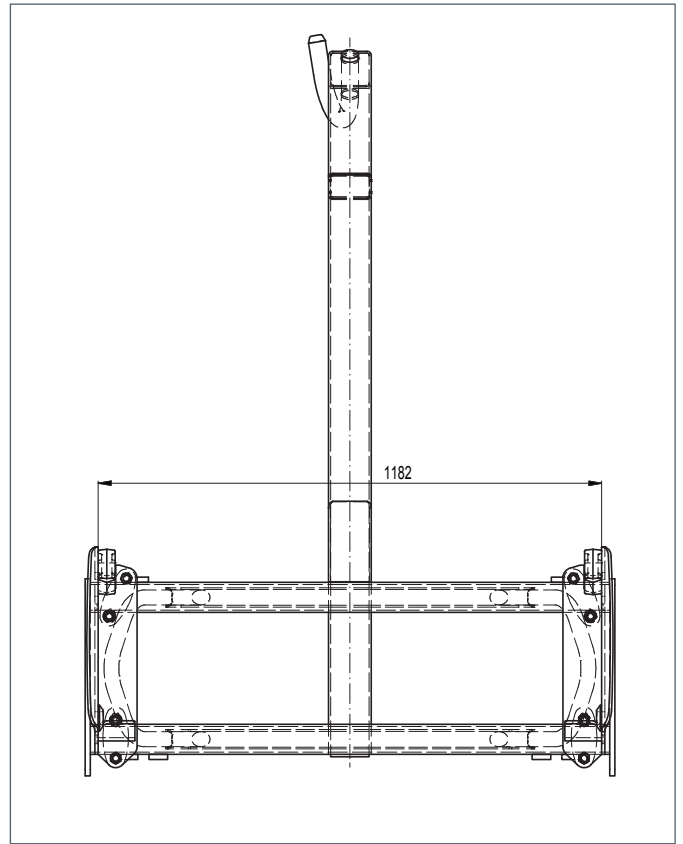

© Hauer 05/2018. Images shown may differ from standard delivery. Errors excepted and technical changes reserved.

